

HXR-MC50E

Digital HD Video Camera Recorder

SONY
make.believe



AVCHD

MPEG2 SD



Sony Lens G

Exmor R
CMOS Sensor

MEMORY STICK™

SD
XC™

GPS

Sony is proud to announce the debut of the HXR-MC50E, today's most compact AVCHD professional camcorder. As simple as "just take it and shoot", this high-quality yet easy-to-use camcorder is the best solution for journalism and proof recording. Extremely small, it is loaded with Sony's latest technology, such as the groundbreaking Exmor R™ CMOS sensor which enables subjects to be captured in low light, and it fulfills the needs of journalists and directors who have been waiting for precisely this kind of compact, high-sensitivity professional camcorder. Furthermore, with its 29.8 mm (35 mm equivalent) wide-angle Lens G from Sony and Optical SteadyShot (in Active mode), the user can get close to subjects without worrying about camera shake - the HXR-MC50E is loaded with everything needed for walking and shooting. And, for acquisition of high-quality audio along with high-quality video data, a genuine external microphone, the ECM-CG1S, and an dedicated microphone holder are included.



Wide-angle Lens

Sony's Lens G™ is anything but an ordinary wide-angle lens. This sophisticated lens incorporates Sony's unique optical design technology and quality control, giving exceptional optical performance that's on a par with some of the best lenses in the industry. It delivers class-leading focal length as wide as 29.8 mm in Video mode (35 mm equivalent) and has been optimized to perfectly complement the advanced image sensor and image-processing technology to expand shooting possibilities. Besides being able to reproduce fine details and high color fidelity by using aspheric lenses and ED glass elements, it includes a six-blade iris diaphragm that is nearly circular to ensure beautiful background blur - a highly desired effect in any serious videography. Of course, for even more dramatic wide-angle shooting, using a 0.75x wide-angle conversion lens gives a staggering 22.4 mm focal length in Video mode.



40mm (HVR-A1E)



29.8mm (HXR-MC50E)

Exmor R™

An image sensor is one of the three key devices that determine final image quality in a camcorder. Sony's Exmor R CMOS sensor is capable of producing superb image quality even in low-light conditions. This unique sensor incorporates exclusive back-illuminated technology that places metal wiring beneath the photo diode (light-receiving material), enabling the CMOS sensor to utilize incidental light more efficiently. This effectively doubles the sensitivity in comparison to conventional CMOS sensors, a dramatic boost in sensitivity that gives rise to superb low-light performance that was impossible to achieve previously. Now, users can shoot high-quality footage in bright daylight and record superb video in dimly lit indoor scenes and outdoor night scenes. Furthermore, with the newly improved autofocus in low-light conditions, the camcorder snaps into focus very quickly.



Conventional Model



HXR-MC50E (Exmor R)

External Microphone

The HXR-MC50E comes with a genuine external microphone, the ECM-CG1S. This state-of-the-art monaural microphone allows users to acquire high-quality sound with high directivity. The specifications of this external microphone are ideal for the needs of voice recording in interviews and for news gathering purposes. It is mounted on the camcorder using the included dedicated microphone holder which is attached to the HXR-MC50E.



Supplied Microphone and dedicated holder

Optical SteadyShot™ w/Active Mode

The new Optical SteadyShot with Active Mode ensures smooth movie footage in various shooting situations. In addition, innovative 3-Way Shake-Canceling adds electronic roll stability for even smoother video capture. This latest version of image stabilization technology realizes images that are up to 10x more steady on the wide end than conventional Optical SteadyShot images. As the user zooms in, an intelligent digital image stabilizer starts to blend in and work together with its optical counterpart to effectively reduce camera shake even while zooming. This technology is also able to reduce shake in the rolling direction that commonly occurs when shooting while walking.



SteadyShot off



SteadyShot w/Active Mode on

* On Screen Image Simulated

Manual Dial

Using the easily accessible assignable dial, users can manually adjust key shooting parameters that include Focus, White Balance, Exposure, AE Shift, and Iris priority and Shutter Speed priority. Now, users can take full advantage of the six-blade iris available in Sony's Lens G in this model to achieve a highly desired out-of-focus effect in the foreground or background. Shutter speed can also be controlled to express certain effects, such as the motion of a waterfall, flying birds, etc.



DVDirect & Direct Copy

When the HXR-MC50E is connected to the optional DVDirect Express (VRD-P1) DVD writer via a USB cable, a single press of the One Touch Disc button is all it takes to burn video footage onto a DVD - without using a PC. This model is also equipped with a down-convert function that enables DVD burning to standard picture quality. Users can playback a DVD they just created simply by pressing the Play button on the DVDirect Express when the HXR-MC50E is connected.

Besides storing videos on DVDs, now with Direct Copy users have the option of storing all valuable video data in an external HDD - without using a PC. Users simply connect the HXR-MC50E to an using USB Adaptor Cable (VMC-UAM1 supplied). Videos that have not been copied to the external HDD can be copied with ease.

Easy Archive Solutions

DVDirect



Compatible DVDirect devices
 • VRD-P1
 • VRD-MC6

* Cannot burn AVCHD FX mode recorded files to DVD of AVCHD disc.
 Can burn FX mode to DVD Video downconverting HD to SD. (VRD-MC6 doesn't support downconverting.)

Direct Copy



1. Direct Copy is compatible with USB media that meets the following requirements
 - USB media that meets the USB2.0 requirement.
 - External HDD or USB memory under 2TB. AC powered external HDD is recommended.
 - USB media formatted in the FAT32 file system. In the case when USB media is not in FAT32 file system, reformatting is required and all data will be erased.
- * There may be cases when USB media is not compatible with Direct Copy even when all of the above is satisfied.
2. When using Direct Copy, the camcorder needs to be connected to AC power.
3. Using VMC-UAM1 (supplied) cable when the HXR-MC50E is connected to External HDD.
4. Connection via USB-hub is not supported.

ACCESSORIES

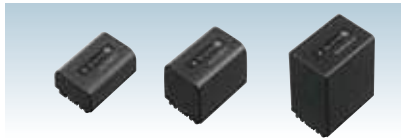

Rechargeable Battery Pack
NP-FV50 (6.8 V / 7.0 Wh / 1030 mAh)
NP-FV70 (6.8 V / 14.0 Wh / 2060 mAh)
NP-FV100 (6.8 V / 26.5 Wh / 3900 mAh)



AC Adaptor/Charger
AC-VQV10
 (AC 100 V - 240 V)



Battery Charger
BC-TRV
 (AC 100 V - 240 V)



Accessory Kit
ACC-V1BP (Include NP-FV100 and AC-VQV10)



Wide Conversion Lens
VCL-HGA07B (0.75x)
 * Must remove supplied lens hood.



Tele Conversion Lens
VCL-HG1737C (1.7x)
 * Must remove supplied lens hood.



PL Filter Kit
VF-37CPKB
 (When shooting through reflective surfaces)
 * Must remove supplied lens hood.

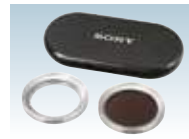

ND Filter Kit
VF-37NKB
 (When shooting in extremely bright sunlight)
 * Must remove supplied lens hood.



Shooting Grip with Mini Tripod
GP-AVT1



Remote Commander
RM-AV2



Memory Stick PRO-HG Duo
MS-HX32A (32 GB, 16 GB, 8 GB)
 Memory Stick PRO Duo
MS-MT32G (32 GB, 16 GB, 8 GB, 4 GB, 2 GB)



SD / SDHC Memory Card
SF-32N4
 (32 GB, 16 GB, 8 GB, 4 GB, 2 GB)



DVDirect Express
 DVD Writer
VRD-P1

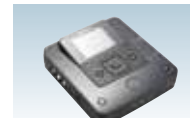

DVDirect
 Multi-Function DVD Recorder
VRD-MC6

Specifications

HXR-MC50E			
General			
Mass	(w / Hood, Microphone w / o Recording Media, Battery)	470 g (1 lb)	
	(w / supplied Battery, Lens hood and Microphone)	670 g (1 lb 7 oz)	
	(w / option Battery NP-FV100, Lens hood and Microphone)	770 g (1 lb 11 oz)	
Dimension (W x H x D)	(w / supplied Hood)	85 x 74 x 176 mm (3 3/8 x 3 x 7 in)	
	(w / supplied Hood, Battery, and Microphone)	85 x 144 x 244 mm (3 3/8 x 5 3/4 x 9 5/8 in)	
Power requirements	Power requirements (AC adaptor / Battery)	8.4 V / 6.8 V	
Power consumption	Viewfinder	HD: 3.2 W / SD: 2.4 W	
	LCD screen (normal brightness)	HD: 3.4 W / SD: 2.6 W	
Operating temperature		0 to +40 deg C (+32 to +104 deg F)	
Storage temperature		-20 to +60 deg C (-4 to +140 deg F)	
Battery operating time	Continuous recording time	approx. 215 min (NP-FV70: fully charged batt.) / 430 min (NP-FV100: fully charged batt.)	
Recording format	Video format	HD	MPEG-4 AVC / H.264 (AVCHD)
		SD	MPEG-2 PS
	Audio format	HD	Dolby Digital 2ch / 5.1ch, 1.6 bit, 48 kHz
		SD	Dolby Digital 2ch / 5.1ch, 1.6 bit, 48 kHz
Recording frame rate*		AVCHD FX (24 Mbps) 1920 x 1080 / 50i / 16:9, AVCHD FH (17 Mbps) 1920 x 1080 / 50i / 16:9, AVCHD HQ (9 Mbps) 1440 x 1080 / 50i / 16:9, AVCHD LP (5 Mbps) 1440 x 1080 / 50i / 16:9, MPEG2 SD HQ (9 Mbps) 720 x 576 / 50i / 16:9, 4:3	
Recording / Playback time		175 min (2 h 55 m) with 32 GB Memory Stick PRO-HX Duo FX (24 Mbps) Dolby Digital 2ch recording	
	Still picture resolution (Photo mode)	12 megapixel 4000 x 3000 (4:3), 4000 x 2250 (16:9)	
Zoom ratio		Sony G Lens, 10x (optical), 120 x Digital Zoom	
Focal length		f = 3.8 to 38 mm (equivalent to f = 29.8 to 298 mm at 16:9 mode, f = 36.5 to 365 mm at 4:3 mode on 35 mm lens)**	
Focus		Full range auto / Manual	
Image stabilizer		Active / Standard / OFF selectable	
Filter diameter		37 mm	
Camera Section			
Imaging device		1 / 2.88-inch type ExmorR CMOS with ClearVid pixel array Pixel Gross: Approx. 6631 K Video Actual: Approx. 4150 K (16:9)	
Minimum illumination		3 lx (Low LUX mode, 1/25 shutter)	
Shutter speed		1/6 - 1/10000 (Manual Shutter Speed Control)	
Iris		F1.8 - F3.4	
Slow & Quick Motion function		200 fps (fixed) as Smooth Slow Rec *The picture quality is degraded.	
White balance		Auto, outdoor (5800 K), indoor (3200 K), One-push (Touch panel)	
Inputs / Outputs			
Mic input		Stereo mini jack (x 1) ø3.5 mm	
A / V Remote Connector		Video / S Video / Audio / Component Out / Remote	
USB		USB device, Mini-B / Hi-Speed (x 1)	
Headphone output		Stereo mini jack (x 1) ø3.5 mm	
HDMI output		HDMI mini connector (x 1)	
Monitoring			
Viewfinder		0.2 inch-type approx. 201,600 dots (300 x 224 x 3 [RGB]), 4:3 aspect ratio	
Built-in LCD monitor		3.5 inch-type, XtraFine LCD, approx. 921,600 dots (1920 x 480), 16:9 aspect ratio	
Built-in Microphone			
		5.1ch Surround or 2ch Stereo microphone	
Recording Media			
Internal Memory		64 GB Flash Memory**	
Type		Memory Stick PRO Duo (Mark2), Memory Stick PRO-HG Duo, Memory Stick PRO-HG Duo HX** SD / SDHC / SDXC Memory Card**	
Supplied Accessories			
		AC Adaptor / Charger [AC-L200], Rechargeable Battery Pack [NP-FV70], Power cord, Microphone (monaural) [ECM-OG1S], Wind Screen, Microphone holder, Lens hood, Remote Commander [RMT-835], Lithium Battery (for Remote Commander) [CR2025], Component A / V cable, A / V connecting cable, USB cable, USB Adaptor cable (for external HDD) [VMC-UAM1], CD-ROM (Application Software "PMB" included)	

*1: Due to variable bitrate, 24Mbps is the maximum bitrate for AVCHD FX mode and the average bitrate is being stated for FH, HQ and LP modes.

*2: The focal length is when SteadyShot mode is in Active mode Off.

*3: When measuring media capacity, 1 GB equals 1 billion bytes, a portion of which is used for system management and/or application files. The capacity that a user can use is approximately 62.8 GB.

*4: Compatible "Memory Stick" type: For AVCHD recording / Capacity: more than 1GB, For Standard Definition recording / Capacity: more than 512 MB

*5: Recommended Speed Class For AVCHD recording / Class 4 or higher, For Standard Definition recording / Class 2 or higher

Recording Time

HD movie (w / 2ch Audio)	AVCHD 24M (FX) (1920 x 1080i)	AVCHD 17M (FH) (1920 x 1080i)	AVCHD 9M (HQ) (1440 x 1080i)	AVCHD 5M (LP) (1440 x 1080i)
2 GB Memory Card	10 min	10 min	25 min	45 min
4 GB Memory Card	20 min	25 min	55 min	95 min
8 GB Memory Card	40 min	55 min	115 min	195 min
16 GB Memory Card	85 min	115 min	230 min	395 min
32 GB Memory Card	175 min	230 min	465 min	790 min
64 GB Internal Memory	360 min	460 min	935 min	1595 min

Dimensions

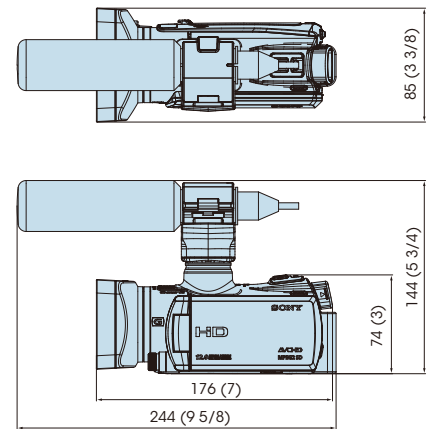

Unit: mm (inches)

Supplied Accessories



PMB System Requirements

- Microsoft® Windows® XP Service Pack3 (32 bit), Windows Vista® Service Pack2 (32 bit / 64 bit), Windows® 7
- Intel® Core™2 Duo 2.26 GHz (for AVCHD playback)
- 1 GB of RAM
- 500 MB available hard-disk space for installation
- 1024 x 768 display
- DVD writable drive
- BD writable drive for Blu-ray video creation

SD movie (w / 2ch Audio)

SD movie (w / 2ch Audio)	STD 9M (HQ)
2 GB Memory Card	25 min
4 GB Memory Card	55 min
8 GB Memory Card	115 min
16 GB Memory Card	235 min
32 GB Memory Card	475 min
64 GB Internal Memory	965 min

Distributed by

MK10690V2OHB10OCT

©2010 Sony Corporation. All rights reserved. Reproduction in whole or in part without written permissions is prohibited. Features and specifications are subject to change without notice.

The values for weight and dimension are approximate. Sony and Sony logo are trademarks of Sony Corporation. G Lens, Exmor, InfolITHIUM, Memory Stick, Memory Stick PRO Duo, Memory Stick PRO-HG Duo are registered trademark of Sony Corporation.

AVCHD and AVCHD logo are trademarks of Panasonic Corporation and Sony Corporation.

Windows is a registered trademark of Microsoft Corporation in the United States and other countries.

Dolby is a trademark of Dolby Laboratories.

SD, SDHC and SDXC logos are trademarks of SD-3C, LLC. All other trademarks are the property of their respective owners.